

DURCO FILTERS

by Ascension Industries

FILTER PRESS

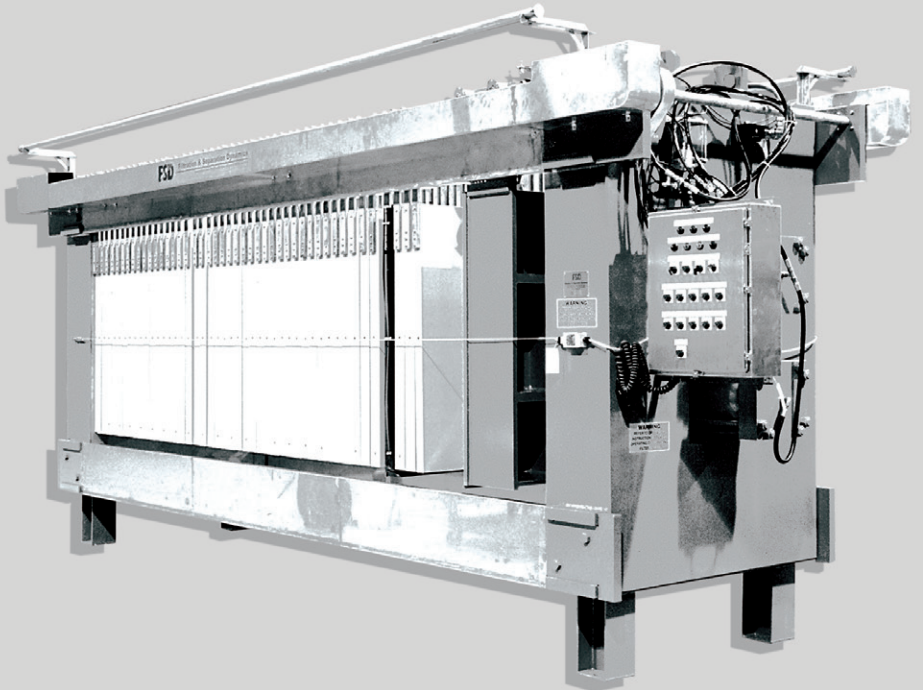
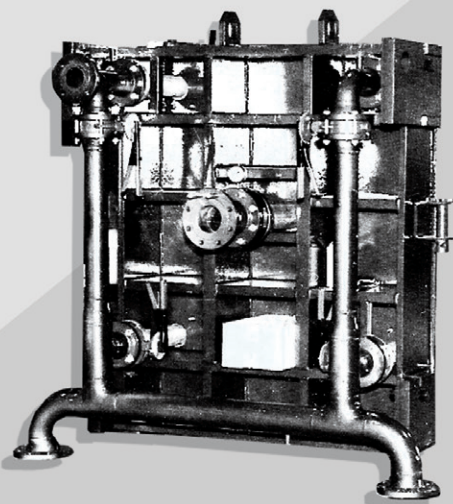
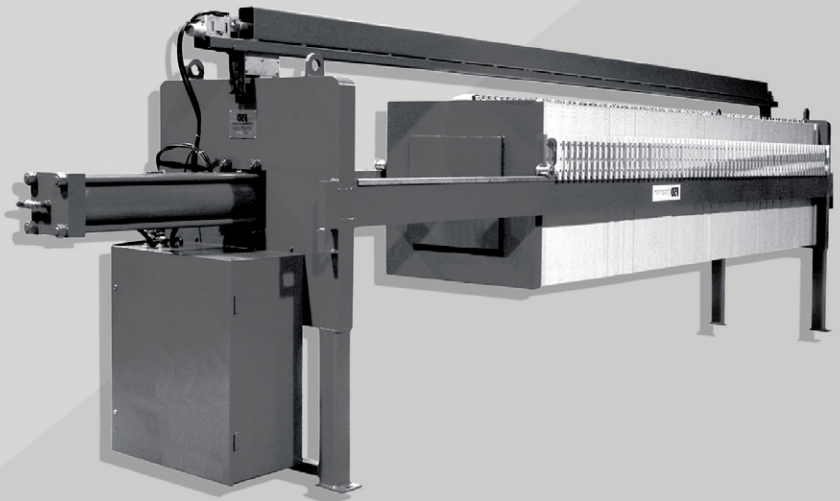
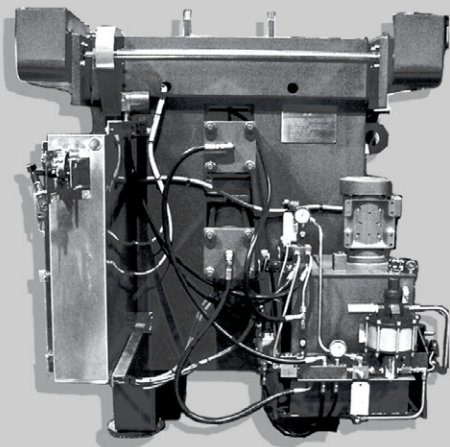

PARTS & SERVICE

Filter Plate Design and Construction

Styles of Construction



Recessed Chamber
(Corner Feed)

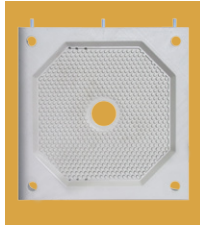

Recessed Chamber
(Center Feed)

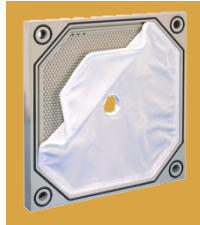

Caulked & Gasketed

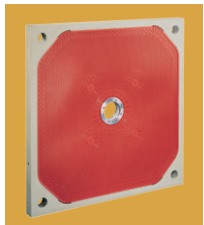

Detachable
Membrane

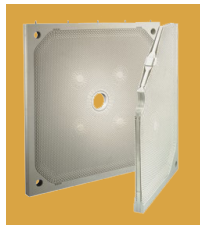

Membrane
& Cutaway

Materials of Construction

Polypropylene - Lightweight, chemically resistant (standard)

Kynar - Chemically resistant and broader temperature range than Polypropylene and Nylon

Metals - Aluminum, Stainless Steel, and Steam Heated

Filter Cloth

<i>Types</i>	<i>Materials</i>	<i>*Cubic Feet/Min (CFM)</i>
Caulked & Gasketed Drapcover	Polypropylene Polyester Nylon Teflon	Available from 1 to wide open

*Filter cloths are typically rated in CFM. Please contact Durco Filters for recommendations on your specific application.

Common Spare Parts

- **Plates** - See above for examples. Average replacement rate of every 5-10 years.
- **Cloths** - See above for specifications. Average replacement rate of every 1 year.
- **Hydraulic Components** - See opposite page for examples.
- **Hangers** - Two configurations available. Replace as needed.
- **Handles** - Replace as needed.
- **Liner Pipes** - Available in Stainless Steel or Polypropylene. Replace as needed.

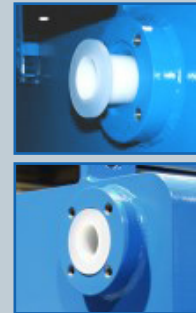

Hydraulic Components

- Air-Driven Hydraulic Booster Pump
- Hydraulic Motor
- Relief Valves
- Release Valves to hold sealing force
- Directional Valves
- Regulator for constant pressure
- Selector Switch (EP Press)
- Air/Oil Filter for electric-pneumatic hydraulic systems

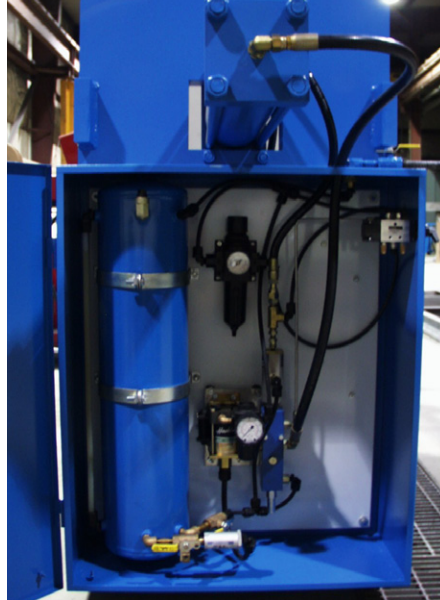

Filter Press Adders

Both models can be retrofitted with:

- Automatic Shifters
- Drip Trays
- Cake Chutes
- Hoppers
- Conveyors
- Full OSHA Platforms
- Access Stairs
- Manual Operation
- Fully-Automatic

Call Durco Filters today to learn about options customized for your application

Upgrades and Replacements

- **Power Units** - available upgrade from pneumatic hydraulic to electric-pneumatic hydraulic, which allows for decreased demand on plant air and shortened press closure times.
- **Hydraulic Parts**
- **Control Panels** - upgrade or replacement available
- **Shifters** - upgrade shifter from semi- to fully-automatic
- **Automation** - valve automation upgrade available for AB processors
- **Incremental Pump Control Optimum**
- **Selector Switch** - replacement for EP presses

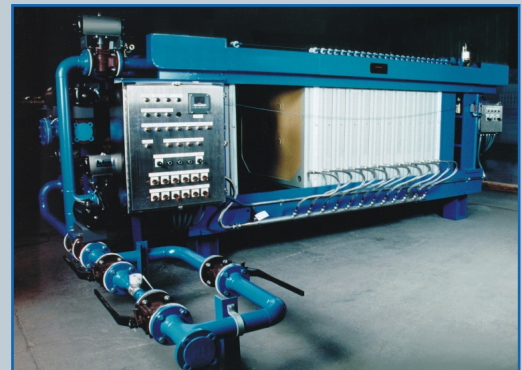
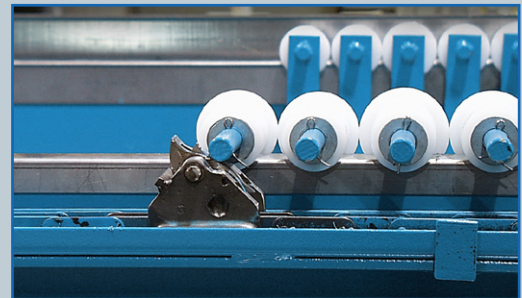

Keeping Your Equipment On-Line

Our highly trained and experienced Field Service Technicians travel world-wide to provide complete support and to keep your equipment running.

System Installation and Startup

The Field Service team from Durco Filters will support you throughout the entire installation and start-up procedure to ensure your satisfaction with our filter equipment.

The Durco Field Service team can help repair and maintain your existing Enzinger, Duriron, FSD, Aquacare and Durco filters or bring old filters back into service.



Equipment Upgrades

The Field Service team from Durco Filters can provide solutions to enhance your system's performance. Often a filter can be optimized for your process cost effectively, avoiding complete replacement. In many cases, Durco's performance enhancements return on their investment in minimal time.

How to Order

Contact one of our helpful Parts Coordinator or an authorized, factory-trained representative near you.

Please be prepared with the order or serial number of your filter when you place a parts order.

Corporate Office

1254 Erie Avenue
North Tonawanda, NY 14120
(P) 716.693.9381 (F) 716.564.9044

Email: filterparts@asmfab.com

Maintenance Agreements

The Durco Field Service team can perform all your routine and preventive maintenance on a schedule that works for you.

Let us customize a plan to meet your needs and virtually guarantee you are never down due to equipment failure.

We have the knowledge, research and experience to identify and repair minor problems **before** they become costly inconveniences or shut down your entire operation.

Training

Improper operation can prematurely shorten the life of or destroy your equipment.

With proper training by our experienced team, you will learn to maximize your filtration operation, while saving both time and money. The Field Service team is available 365 days a year on a 24-hour basis to provide the training necessary to cover all aspects of your system's operation. Call us with any questions today!

Ascension Industries, Inc.
1254 Erie Avenue
North Tonawanda, NY 14120
www.durcofilters.com

Phone: 716.693.9381
Fax: 716.564.9044

sales@asmfab.com
filtersales@asmfab.com